

VMotionBe

Machinerie intégrée en partie basse

*Integrated machineroom
in low part of the shaft*

400/450/630/1000/1275/1600/2000 kg

APPAREILS COMPLETS
COMPLETE LIFTS



Configurations et dimensions possibles

Configurations and dimensions available

Simple accès - Porte télescopique

Single access - Telescopic door

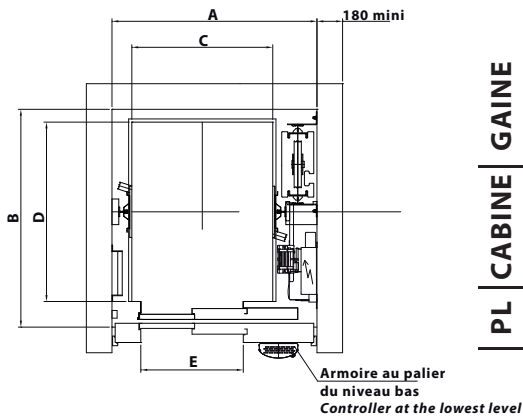

		400 kg	450 kg	630 kg	1000 kg	1275 kg	1600 kg	2000kg
		5	6	8	13	17	21	26
GAINÉ SHAFT	A	1500	1500	1600	1600	1950	2250	2250
	B	1500	1550	1700	2400	2600	2700	3000
CABINE CAR	C	1000	1000	1100	1100	1250	1400	1500
	D	1100	1250	1400	2100	2300	2400	2700
PL CO	E	800	800	800/900	900	1100	1300	1300

Simple accès - Porte centrale

Single access - Central door

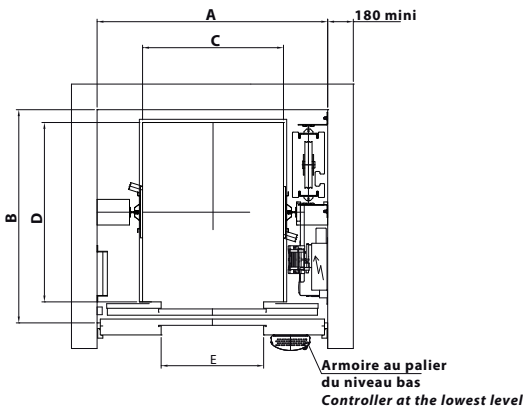

		450 kg	630 kg	1000 kg	1275 kg	1600 kg	2000kg
		6	8	13	17	21	26
GAINÉ SHAFT	A	1800	1800	1950	2350	2260	2250
	B	1550	1700	2400	2600	2700	3000
CABINE CAR	C	1000	1100	1100	1250	1400	1500
	D	1250	1400	2100	2300	2400	2700
PL CO	E	800	800	900	1100	1300 (4 vantaux 4 panels)	1300 (4 vantaux 4 panels)

Double accès - Porte télescopique

Double access - Telescopic door

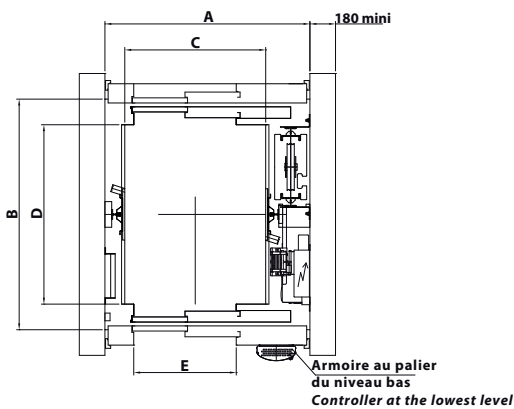

		450 kg	630 kg	1000 kg	1275 kg	1600 kg	2000kg
		6	8	13	17	21	26
GAINÉ SHAFT	A	1500	1600	1600	1950	2250	2250
	B	1700	1800	2500	2700	2800	3100
CABINE CAR	C	1000	1100	1100	1250	1400	1500
	D	1300	1400	2100	2300	2400	2700
PL CO	E	800	800/900	900	1100	1300	1300

Double accès - Porte centrale

Double access - Central door

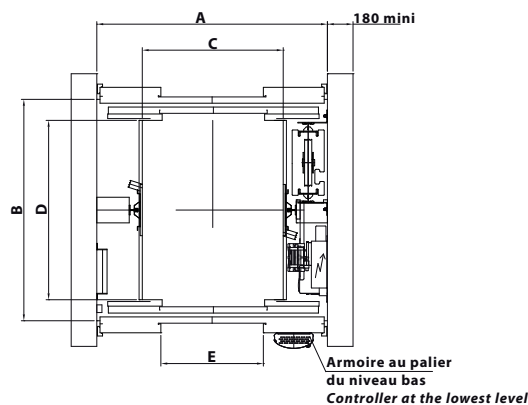



		450 kg	630 kg	1000 kg	1275 kg	1600 kg	2000kg
		6	8	13	17	21	26
GAINÉ SHAFT	A	1800	1800	1950	2350	2260	2250
	B	1650	1750	2450	2650	2800	3100
CABINE CAR	C	1000	1100	1100	1250	1400	1500
	D	1300	1400	2100	2300	2400	2700
PL CO	E	800	800	900	1100	1300 (4 vantaux 4 panels)	1300 (4 vantaux 4 panels)

ASCENSEURS
OLEOLIFT



13 rue Joseph Paxton
ZAC du Parc du Bel Air
77164 FERRIERES-EN-BRIE
FRANCE

 +33(0)1 60 17 05 15
 +33(0)1 60 05 33 75
www.oleolift.fr

27 000 014



FABRICATION FRANCAISE

FR

UK

